

AN ELECTRICITY EMISSION FACTOR

1 INTRODUCTION

Concept Consulting Group (Concept) has been asked by the Climate Change Office to estimate an “electricity emission factor” for a supply and demand scenario over the period 2008 to 2012, the initial Kyoto commitment period. This report describes the approach taken, factors affecting CO₂ emissions, key assumptions and the results of this work.

2 THE CONCEPT OF AN ELECTRICITY EMISSION FACTOR

It is understood that the electricity emission factor is to be used in estimating the likely reduction in carbon dioxide (CO₂) emissions from thermal power stations between 2008 and 2012 should new renewable supply or alternative demand side initiatives be supported during the forthcoming Climate Change Office tender round.

The electricity emission factor is to be a generic estimate and assessment of any project would need to take into account any offsetting emissions associated with the project. For example, in considering a geothermal electricity supply project proposal, the evaluation of the project’s overall emission impact would need to account for any CO₂ emissions expected from the project itself. Similarly, on-site emission implications would need to be included in the evaluation for any demand side proposals with associated emissions.

3 APPROACH

In undertaking this assessment, a set of electricity supply and demand assumptions to 2012 was developed in consultation with Climate Change Office and Ministry of Economic Development staff. Given these assumptions, Concept used its electricity market model to assess likely power station operating patterns over the period 2008 to 2012. In order to assess how thermal electricity supply patterns would be affected by the addition of renewable electricity supply over the period, an increment of 50MW of continuous supply was added to the base supply and demand scenario. Changes in CO₂ emissions were then estimated from the changes in thermal operating patterns for each set of model results. Some sensitivity analysis was also undertaken in relation to key assumptions.

An increment of 50MW continuous supply was chosen to ensure that a discernable effect would be observed and so that the analysis would be broadly consistent with an overall tranche of energy likely to be considered in the initial projects tenders round. A similar assessment was undertaken by reducing renewable supply in the base scenario by 50MW continuous supply to confirm consistent results.

Note that the 50MW continuous supply increment modelled is not intended to represent any particular project. In fact in terms of annual energy supply, it equates roughly to a

typical 120MW wind-farm or a 55MW geothermal power station operating for 90% of the time at full capacity.

Before describing the scenario assumptions, the modelling framework and results, it is useful to consider the key factors which influence CO₂ emissions from thermal power stations and the demand for supply from thermal power stations.

4 THERMAL ELECTRICITY CO₂ FACTORS

CO₂ is one of the key greenhouse gases. It is produced when coal, gas or oil is burned. The amount of CO₂ produced depends on the type of fuel as shown in Table 1 (noting that the factors for some fuels, such as oil or distillate, may vary with fuel composition).

Kg of CO ₂ per Gigajoule (kg /GJ)	
Waikato Coal	91
Natural Gas	52
Heavy Fuel Oil	75
Distillate	69

Table 1: Carbon Content of Fuels

In burning fossil fuels, thermal power stations emit CO₂. The amount of CO₂ emitted for each unit of electricity produced depends in part on the type of fuel as noted in Table 1.

It also depends on the thermal efficiency of the power station technology involved, the extent to which the energy content in the fuel source can be converted into electrical energy without losses. The combined effect of these factors is reflected in Table 2, which shows the typical amount of CO₂ produced in making a unit of electricity for different types of thermal power stations used in New Zealand.

CO ₂ per Megawatt-hour of Electricity (Kg/MWh)	Gas	Oil	Coal
Open Cycle Gas Turbine ¹	570	710	
Steam Cycle Power	530	820	930
Combined Cycle Power	370		
Cogeneration ²	250		440

Table 2: Typical Thermal Power Station CO₂ Factors

¹ Open cycle gas turbines have been included because government has recently announced it has entered commercial arrangements with Contact Energy for a dry year security plant, likely to be sited at Whirinaki by winter 2004.

² The actual figure for cogeneration depends on the relative proportions of electricity and process heat produced.

For each type of power station, actual CO₂ factors will vary slightly due to variations in thermal efficiency at each station and fuel quality.

5 FACTORS AFFECTING THERMAL ELECTRICITY SUPPLY REQUIREMENTS

The level of thermal electricity supply required at any time depends on the overall demand for electricity and the availability and cost of alternative electricity supply. Over time, as the availability and cost of energy resources and technologies change, the relative economics of various electricity supply options will alter. The actual mix of electricity supply sources can therefore be expected to alter over time as well. However, the nature of the New Zealand electricity supply system means that for the foreseeable future electricity supply will continue to be dominated by hydro power, in turn influenced directly by the weather. Combined with seasonal and daily electricity demand patterns, this means that in any year, and especially over shorter timeframes, the actual mix of supply required can vary significantly. Key factors influencing shorter term requirements for thermal electricity supply are therefore considered first.

5.1 Electricity Demand Patterns

The demand for electricity varies during the year, as shown in Figure 1.

Figure 1: Weekly NZ Electricity Demand (2002)

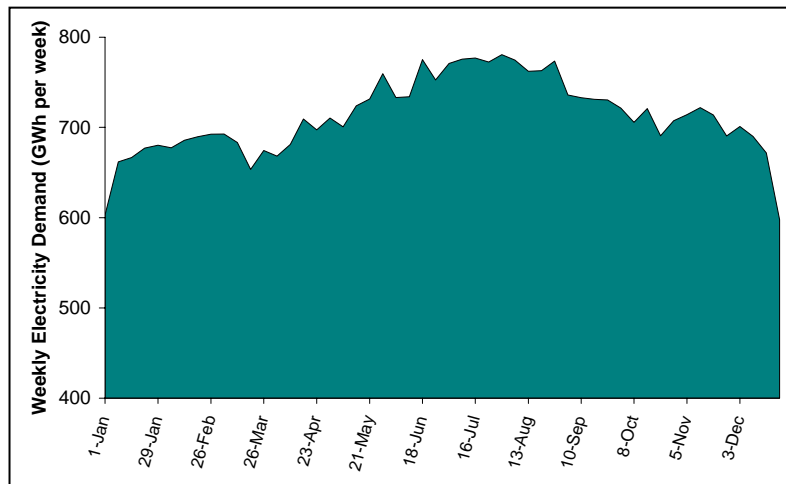

Electricity demand is highest over the winter months, when heating and lighting requirements are greater. Demand is lowest over the summer months, and especially over the holiday period when industry and commerce activity levels reduce. Total electricity supply must therefore vary from season to season to match overall electricity demand.

Electricity demand also varies during each day and from day to day as illustrated in Figure 2. Demand is lowest overnight when commercial and industrial activity reduces.

Demand peaks occur each morning and evening, largely due to heating and cooking requirements on top of the normal level of commercial and industrial activity during the daytime.

Figure 2: Typical Day to Day Electricity Demand Pattern

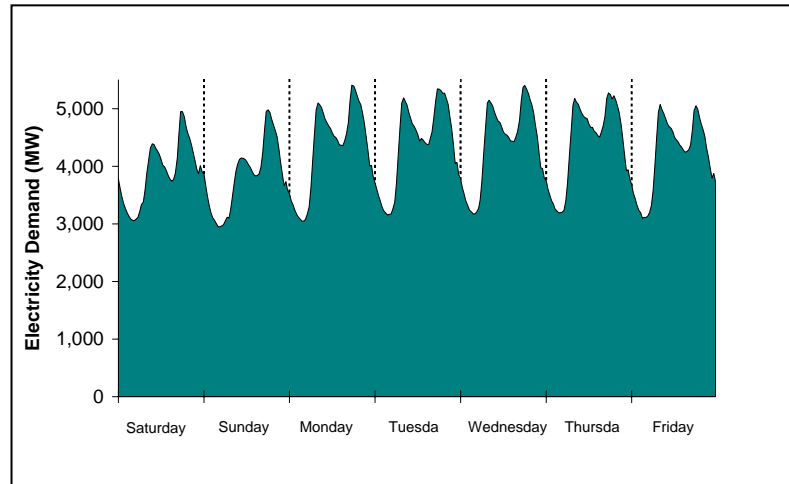

Because different thermal power stations have different CO₂ factors, the order in which power stations are used to meet increases or reductions in demand, including hydro power stations, will influence the level of CO₂ emissions at any particular time. For example, if a change in demand of 1MWh were to be matched solely by Huntly power station operating on coal, CO₂ emissions would change by 0.93 tonnes. On the other hand, if the change in demand was met by hydro only, there would be no change in CO₂ emissions, at least for that particular period. However, there could be an effect in later periods if the MWh supply reduction related to water being conserved in hydro reservoirs for future use.

Effects like these need to be considered in analysing the impact of additional renewable supply in order to answer key questions relating to an electricity emission factor. In which periods would thermal generation be displaced by additional supply? At which stations? What would be the cumulative impact on total emissions each year? How would total emissions differ over the entire period from 2008 to 2012?

Another major factor influencing emissions, and more significant in the New Zealand context, is the mix of available alternatives to thermal electricity supply.

5.2 Overall Electricity Supply Mix

On average, around 60% of New Zealand's electricity demand is at present supplied from energy sources that do not contribute to the greenhouse gas inventory – mostly hydro power stations. The remaining electricity demand is met from a mixture of geothermal, natural gas, coal and oil fired power stations.

Figure 3 reflects sources of electricity supply during an average year.

Figure 3 : Typical Electricity Supply Sources

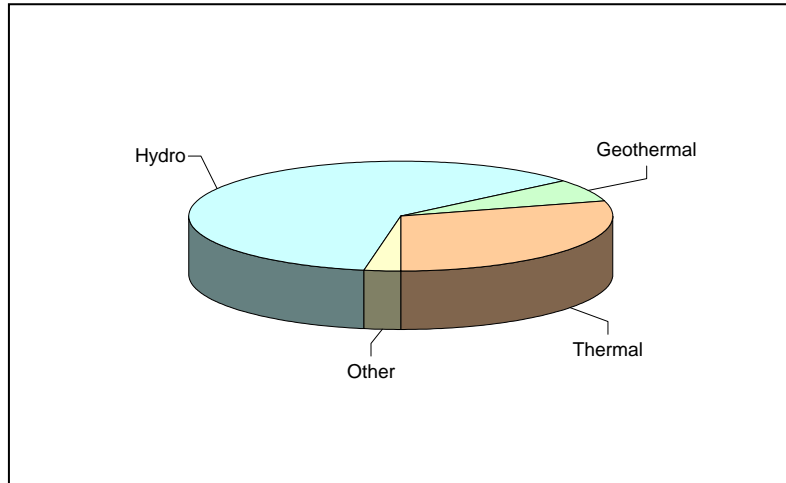

5.3 Hydro Supply Variability

Because hydro inflows are dependent on rainfall and snow melt, total hydro electricity supply can vary significantly each year and even more over shorter timeframes. Figure 4 illustrates how hydro inflows can vary within a year. It shows how the potential electricity supply available each week from total inflows into the major hydro systems can vary.

Figure 4: Short Term Hydro Inflow Variability

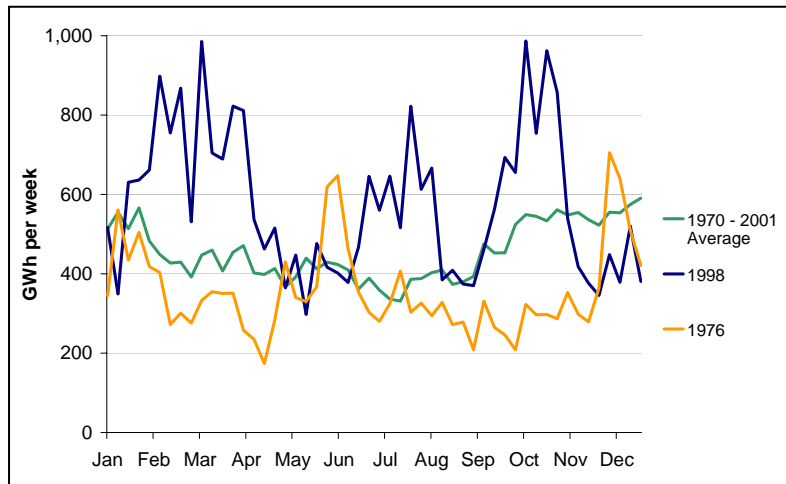

The storage capacity of New Zealand’s hydro lakes tends to smooth out some of this inflow variability. That is, depending on prevailing supply and demand conditions, hydro electricity generators can supplement low inflows with releases from the storage lakes or, if inflows are high, can hold water in storage for later use. However, hydro storage is only about 10% of annual electricity demand when reservoirs are all full. The ability to smooth out inflow variability and to manage hydro storage to match hydro supply to electricity demand is therefore limited when compared to the annual variability of potential electricity supply.

Further, over 40% of hydro inflows are typically tributary or uncontrollable flows and do not pass through the major hydro storage lakes. This also limits the ability of hydro storage to smooth out inflow variability. Minimum flows required under resource consents can also be a limiting factor.

The impact of hydro supply variations on the demand for non-hydro electricity supply is shown in Figure 5.

Figure 5: Effect of Hydro Variability on Other Supply Requirements

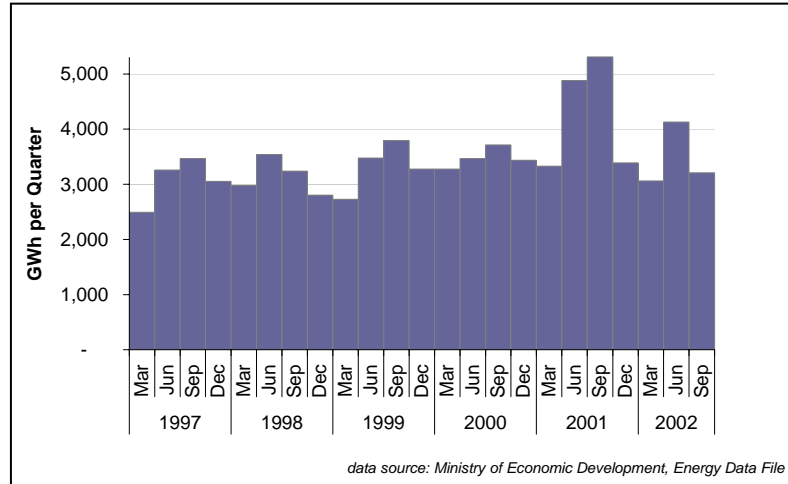

Figure 5 shows quarterly non-hydro electricity supply between 1997 and 2002. Because hydro supply is such a large proportion of total supply, hydro variations have a proportionately larger impact on the requirement for non-hydro supply. For example, in Figure 5, the difference between the lowest and highest level of non-hydro supply in the quarter ending March was approximately 900GWh. This is equivalent to the amount of energy that can be produced over a three month period by approximately 400MW of thermal supply. As can be seen in Figure 5, the difference between supply in other quarters was substantially more. The sample spans just six years of actual data and greater variability can be expected.

5.4 Implications of Hydro Variability

In a 'wet' hydro year, the current requirement for non-hydro supply can therefore fall almost as low as 30% of annual supply. In a dry hydro year, the requirement for non-hydro supply can be of the order of 50% of annual supply. There can also be a significant requirement for short-term non-hydro supply flexibility to compensate for uncontrollable inflow variability.

Apart from hydro electricity supply schemes with storage, non-thermal electricity supply options tend to be inflexible. That is, electricity is produced whenever energy resources are available to the plant rather than being scheduled in response to electricity demand and prices. For example, wind-farms generate electricity when the wind blows and

geothermal power stations tend to be base loaded, operating at the capacity of the geothermal field whenever the plant is available.

Energy supply from hydro power stations is largely a function of the weather attenuated only where storage lakes exist. Hydro schemes typically have reasonable flexibility to store inflows within a day so as to match supply to peak demand requirements. However, responding to hydro variability in matching electricity demand over longer periods relies significantly on thermal power station flexibility.

5.5 *The Role of Thermal Supply*

At present, the requirement for thermal electricity supply in a dry hydro year can be roughly double that in a wet year. The amount of CO₂ emissions can therefore be expected to vary considerably from year to year depending on the weather.

Over the longer term, and certainly during the period 2008 to 2012, flexible thermal supply will continue to be an important part of the NZ supply system. To put that into context, the difference between wet year and dry year hydro supply capability is similar to the annual production of two combined cycle power stations or three of Huntly power station's four generating units. As the overall mix of supply alters over time, the average amount of thermal supply needed in any year may alter but the overall need for this level of flexible thermal supply will not change unless offsetting factors materialise, such as increased hydro storage or significant demand side flexibility. This seems unlikely to occur to any significant extent during the study period.

The order in which thermal power stations increase or decrease production in response to hydro variability, and the fuels used, can impact significantly on the level of CO₂ emissions as evident from the data in Table 2 on page 2.

5.6 *Supply Cost Factors*

New power station investments are based on expectations that electricity prices will be sufficient to make a commercial return over and above the full costs of building and operating the plant. The mix of power stations, and therefore overall CO₂ emissions, can be expected to change over time depending on investor expectations of electricity prices relative to the availability and cost of the different supply options. Developing the core set of supply and demand assumptions for 2008 to 2012, discussed later, needs to take these factors into account.

However, once a power station has been built, the cost of producing each additional unit of electricity - the variable cost – can be an important factor in determining when and how much the plant will run. This is particularly so in New Zealand where the availability of hydro supply varies considerably and as a result wholesale electricity market prices are relatively volatile. Wholesale electricity market prices tend to fall when hydro supply is plentiful and vice versa. When prices fall, power stations with high variable operating costs will tend to reduce output and may shut down altogether if prices are sufficiently low. As electricity market prices rise, it will be more economic for power stations with higher variable costs to operate.

While relatively expensive to construct, the operating costs of hydro power schemes are largely fixed and the cost of producing an additional unit of electricity is small. This means that once a decision has been made to build a hydro power station, it will operate whenever water is available unless inflows can be held in storage reservoirs to use at a time when hydro supply is more valuable (when market prices are higher). Other renewable supply options, such as wind-farms or geothermal power stations, also have relatively low variable costs and their operation is largely governed by the availability of energy supply to the plants rather than prevailing electricity market prices.

In contrast, the cost of building a thermal power station of comparable capacity tends to be less expensive than hydro or other renewable supply options. However, the variable costs of operating a thermal power station can be relatively high because each unit of electricity produced requires fuel. The level of variable cost at a particular thermal station depends on both the fuel cost and the efficiency of the plant involved. In some cases, thermal power station fuel contracts have take or pay components which means that the actual variable cost of producing each unit of electricity can be relatively small at times, depending on the ability to store or bank the fuel for later use (or possibly on-sell it).

Accordingly, for the same fuel cost or opportunity value placed on the fuel in terms of alternative uses, thermal power stations with higher efficiency will tend to operate more than less efficient plants. For example, cogeneration plants have relatively high overall efficiency because some of the heat produced in making electricity is used for industrial or other heating purposes. These plants tend to operate at constant output most of the time typically only shutting down for maintenance and / or when there is no demand for steam at the host site. On the other hand, less efficient plants, especially where fuel costs are high, operate less and at times not at all. For example, as can be seen in Figure 6, the price or perceived opportunity cost of fuel at a steam cycle power station, such as New Plymouth or Huntly, would need to be about 70% of that at a modern combined cycle power station, such as Otahuhu B, to achieve the same variable cost of fuel for each unit of electricity produced.

Figure 6: Impact of Fuel Cost on Variable Operating Costs

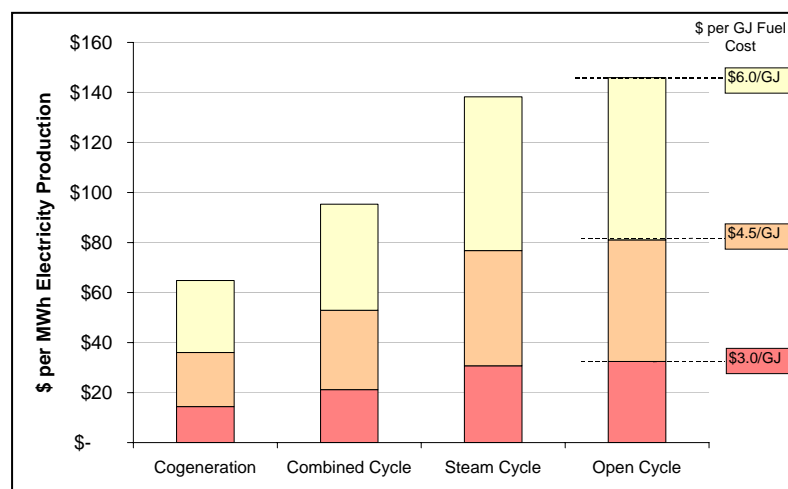

The introduction of domestic carbon charges from 2007 will increase the variable operating costs of thermal power stations with the relative cost impact at each station

reflecting the CO₂ factors in Table 2. Figure 7 illustrates the effect for a carbon charge of \$15 per tonne of CO₂. For example, a carbon tax of \$15 per tonne of CO₂ could be expected to add around \$14 per MWh to the variable operating cost of Huntly power station on coal and around \$5.6 per MWh to that of a combined cycle gas power station.

Figure 7: Incremental Effect of \$15 per tonne of CO₂ Carbon Charge on Variable Electricity Production Cost

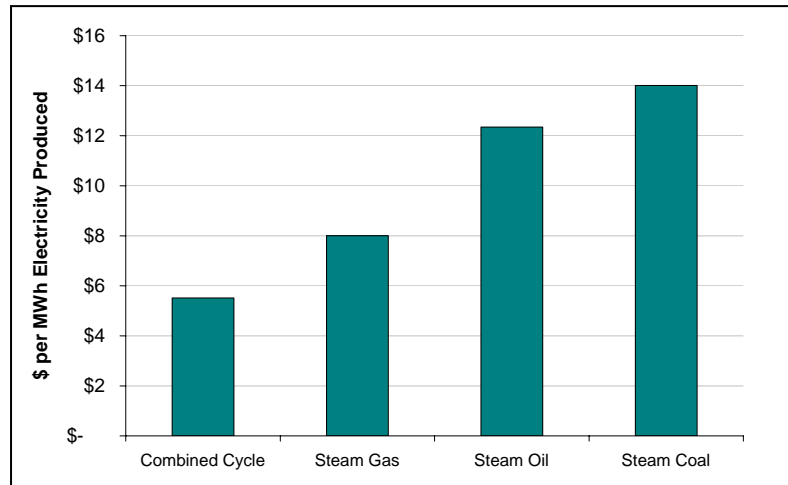

These factors will tend to be reflected in the offers generating companies make for supply into the electricity market to secure company revenue requirements. That is, they will influence the order of dispatch in the electricity market especially at times of oversupply, such as wet hydro sequences, when wholesale electricity market prices can fall significantly. Only a portion of the overall revenue of an electricity generating company is from wholesale spot market sales. The combination of retail customers and wholesale supply contracts mean that a substantial portion of the company's revenues tends to be regarded as fixed. However, generators can still increase or reduce supply offers in response to prevailing electricity market conditions so as to optimise overall profits. For example, if wholesale electricity prices fall below the variable cost of production at a particular power station, then it would be profitable for the generator involved to buy supply from the wholesale market to meet its contractual commitments to customers rather than to generate itself at a loss. When wholesale electricity prices rise, it would be profitable for a generator with high variable fuel costs and/or with access to additional profitable fuel to offer additional supply into the spot market.

6 NOMINAL ELECTRICITY SUPPLY AND DEMAND SCENARIO

A base supply and demand scenario was developed for this assignment in consultation with Climate Change Office and Ministry of Economic Development staff.

Gross electricity demand, the requirement for total supply including transmission and distribution losses, has been modelled. A figure of 41,240GWh has been assumed for

the 2003 year³. Electricity demand growth of approximately 2% per annum through to 2012 has been assumed, consistent with the average historical growth rates.

Following the Maui gas contract redetermination, it has been assumed that during the period 2008 - 2012 there will generally only be sufficient gas for existing combined cycle power stations plus the proposed Genesis e3p project planned at the Huntly site. The overall gas supply outlook, at least over the period to 2012 given the long lead times to develop any significant new gas reserve discoveries, is now increasingly dependent on development of the Pohokura and Kupe fields. Pohokura reserves have also been revised downwards from original estimates.

Given the current gas supply situation, Contact Energy has announced that its second combined cycle gas turbine plant at Otahuhu, for which resource consents have been secured, will not proceed as originally planned around 2007/8. Contact Energy has also recently restored oil firing capability at New Plymouth power station. Genesis Power has announced an 8 year coal supply contract with Solid Energy. Over the period 2008 to 2011, the supply of 1.7m tonnes of coal per annum to Huntly power station is expected under that contract. That is enough coal to operate two 250MW Huntly generating units for around 85% of the year. Genesis is also seeking to establish the capability to import additional coal through the port of Tauranga and has imported some trial shipments of coal in 2003.

A number of new electricity supply initiatives are currently planned to be in place before or during the period 2008 to 2012. For example, Trustpower and Meridian Energy have each committed to wind-farm projects; Genesis Power has announced it plans to construct its e3p combined cycle power station (2006) subject to securing suitable gas supply arrangements; and Meridian Energy is about to enter the resource consent phase for its planned Project Aqua hydro scheme to supplement the Waitaki hydro scheme in the South Island (in two stages between 2008 and 2012).

For the purpose of this study, it has been assumed that these projects will proceed. Some other smaller new supply projects that have been announced and appear reasonably likely to proceed have also been included.

A number of potential new electricity supply projects have been suggested publicly but are considered less certain to proceed and have not been specifically included. Instead, on the assumption that at least some of these proposals are likely to proceed, generic increments of new supply have been added prior to and during the 2008 to 2012 study period. These increments have been added taking into account existing supply, likely new supply projects, a \$15 carbon tax⁴ from 2008, and gas and coal assumptions. Supply and demand remain in reasonable balance over the period to 2012 but it is

³ The figure has been normalised to remove the impact of demand reductions as a result of the 2003 winter security situation. The gross demand figure includes industrial supply to satisfy on-site demand.

⁴ We understand that a carbon charge will be set at a level approximating the world price of Kyoto emission units, but capped at \$25 per tonne of CO₂. Estimates of the likely price range vary, but an intermediate figure of \$15 has been used for this analysis.

assumed that supply will grow slightly more than demand over the period reflecting increasing costs of new supply, including carbon tax effects and gas prices of the order of \$5 per GJ, and therefore higher electricity prices. The latter will make a number of otherwise uneconomic small supply options more attractive.

New supply assumptions are set out in Table 3.

MW	to 2008	2009	2010	2011	2012
Combined Cycle	360	-	-	-	-
Geothermal	155	10	10	10	10
Hydro	312	-	-	-	262
Wind	164	20	20	20	20
Other	30	5	5	5	5

Table 3: New Supply Assumptions

Dry year security reserve supply has not been included specifically in the analysis. It is intended to operate infrequently to cover dry year security risks and should therefore only influence power station CO₂ emissions in very dry years, and even then only as a small part of the overall thermal portfolio. It should therefore not materially impact on the average level of emissions.

7 ANALYSIS

The base supply and demand assumptions have been modelled in detail over the period 2007 to 2012 using Concept's electricity market model EMOS. A start date of January 2007 was used to ensure that a realistic range of hydro storage levels would be achieved by January 2008, the start of the commitment/ study period.

The assumed supply and demand scenario was assessed over a representative range of hydro inflow events using inflow sequences into each of the hydro catchments between 1971 and 2001.

EMOS models supply and demand in each Island as a number of blocks reflecting typical demand patterns within each week over each year. Each of the hydro systems, including the main storage reservoirs, and thermal generating units are included. EMOS constructs a set of electricity market offers each week reflecting thermal generation offers and hydro storage guidelines/water values. Thermal generation offers have been tuned to reflect the likely relative fuel costs at each station taking into account the likely nature of fuel contracts and likely opportunity costs of any assumed take or pay obligations.

The nature of the contracts that thermal generators have for their fuel supplies is important in determining which of them will generate in any given circumstances. Each coal or gas supply contract will have a mix of take-or-pay and flexible provisions. The recently signed Huntly coal contract is particularly significant. It provides for the supply

of 1.7m tonnes of coal per annum over the period 2008 to 2011. It is assumed to have some significant flexibility.

The coal supply contract details are not known but it is likely that in addition to the coal stockpile at Huntly there will be some physical stockpile capability external to the site. Accordingly it has been assumed that on an annual basis, a significant portion of Genesis' coal will be burned on a take or pay basis at a level similar to the annual capability of two Huntly units. In addition to coal stockpiling capability on and off site, some commercial flexibility to carry over coal into a subsequent contract year has been assumed. For particularly dry hydro sequences, or where inflows over multiple years are lower than average, the nominal supply and demand scenario assumes that Genesis would be able to procure additional coal supply or possibly draw on the next year's allocation.

Within each contract year, it has been assumed that coal burn flexibility will be greater. In other words, while annual coal burn is expected to be relatively high, there will be reasonable flexibility during the year to increase or reduce Huntly supply in response to market prices.

As discussed on pages 5 and 6, hydro variability means that flexible thermal supply is important. In the past, the large Maui gas supply contract has provided substantial flexibility in thermal supply. However, future gas supply arrangements are expected to be significantly less flexible than under the Maui regime. In addition, a carbon charge would increase the variable cost of electricity supply from coal significantly more than for gas as illustrated in Figure 7 on page 9. It has therefore been assumed that electricity supply from coal will tend to be relatively more flexible than electricity from combined cycle gas during wet hydro years, and will play an important role in terms of dry year flexibility. However, it has also been assumed that there will be some flexibility in the combined cycle power station gas supply contracts so that during wet hydro years, supply would reduce if prices fall sufficiently.

Unless there is some flexibility in gas supply and coal supply, typical hydro variability cannot be accommodated without the potential for significant spill. Electricity market prices can therefore be expected to fall to the point where thermal supply would reduce, noting that the variable operating costs of thermal stations are high compared to a hydro scheme. Significant hydro spill would otherwise be inevitable. Conversely, as hydro dry year risks are perceived to rise, electricity market prices would rise to encourage higher cost thermal supply options such as New Plymouth on oil.

In the analysis, consistent with the above, thermal offers result in a high level of annual coal burn, with reasonable flexibility within each year to stockpile coal, and additional combined cycle plant turndown flexibility. Figure 8 illustrates how, for the assumed level of flexibility, coal requirements would vary under the base scenario. The chart tracks variations in notional coal stocks where zero represents the nominal stock level target at the start of 2008.

Negative values represent additional coal that would need to be procured to maintain stocks at the target level. Positive values represent stock increases (on and off site and possibly commercial arrangements to defer coal deliveries to subsequent years depending on the level of stock that can be physically accommodated).

Figure 8: Coal Flexibility Assumptions In Relation to Hydro Variability

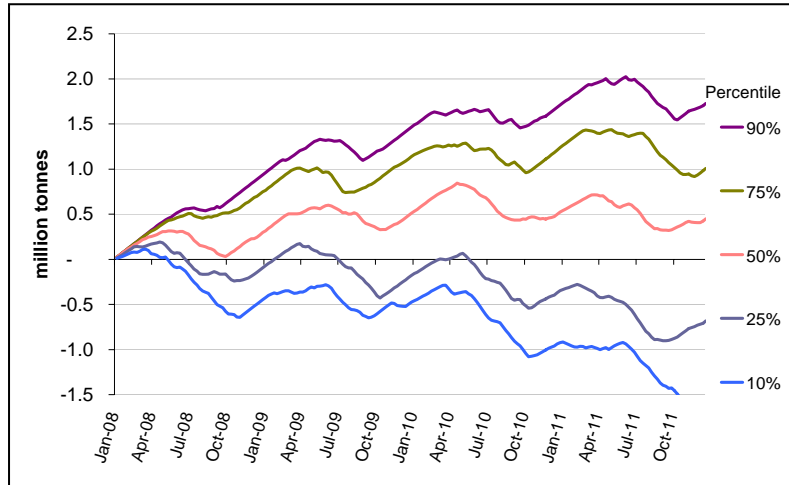

It has been assumed that New Plymouth would operate on oil in dry years after Huntly coal and the combined cycle plants.

The nominal scenario was modelled with and without a 50MW tranche of continuous new renewable supply as described on page 1 and summarised again in Figure 9.

Figure 9: Approach to Analysis

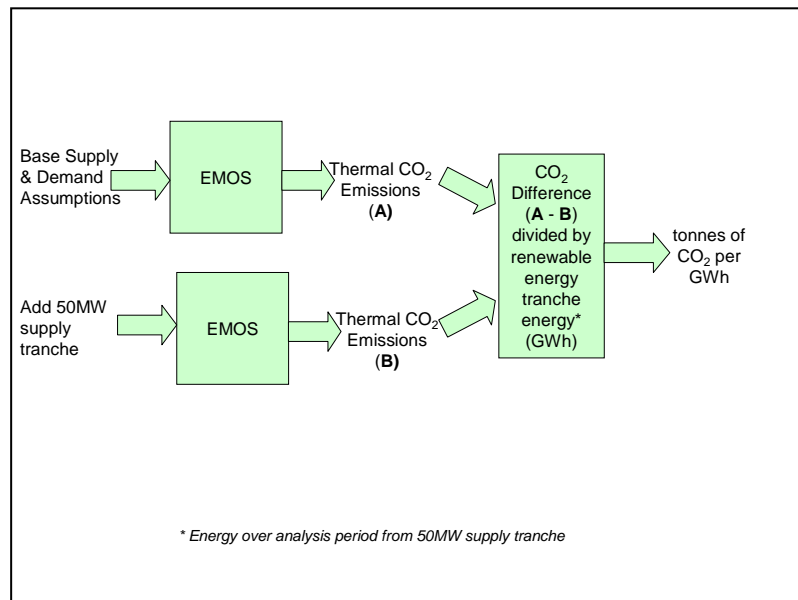

As depicted, the differences in production at each thermal power station as a result of the addition of the tranche of new supply were analysed and converted into net CO₂ emissions per GWh of additional renewable supply.

Figure 10 shows the range of emission factors that could be expected for the 31 inflow sequences over the period 2008 to 2012 including for the individual years. Each curve

indicates the likelihood⁵ of a particular emission factor being exceeded, given the full range of hydrological sequences. This has been done for each of the five years in the commitment period, with their different levels of demand and corresponding supply mix, and for the commitment period as a whole.

Figure 10: Emission Difference vs Hydrology (base scenario)

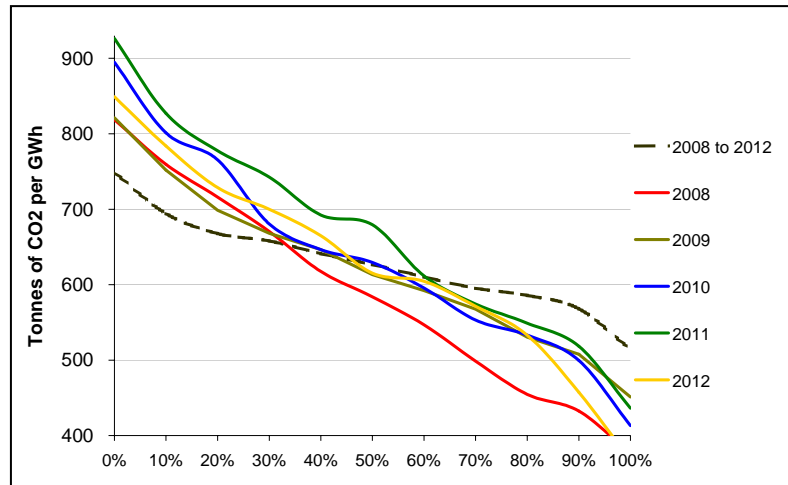

In any one year, the emission factor ranges between 400 and 900 tonnes per GWh depending on hydrological variability. Over the full five years, the annual variability is attenuated significantly although there is still substantial variation driven by year-to-year changes in hydrology.

The median five year value, approximately 630 tonnes of CO₂ per GWh, is seen to be more consistent with an assessment of the impact of a tranche of renewables over the initial commitment period of 2008 to 2012.

Similar analysis was undertaken by removing a 50MW tranche of continuous renewable supply. The increase in average tonnes of CO₂ per GWh of renewable electricity supply removed matched closely the reduction in the emission factor when the 50MW tranche was added. This linearity over a 100MW range suggests that the analysis is likely to be relatively robust for a tranche of additional supply larger than 50MW.

Figure 11 shows how the average change in CO₂ emissions per GWh alters for each quarter over the study period.

⁵ Calculated as percentiles.

Figure 11: Expected Quarterly and 2008 to 2012 Emissions Change per GWh

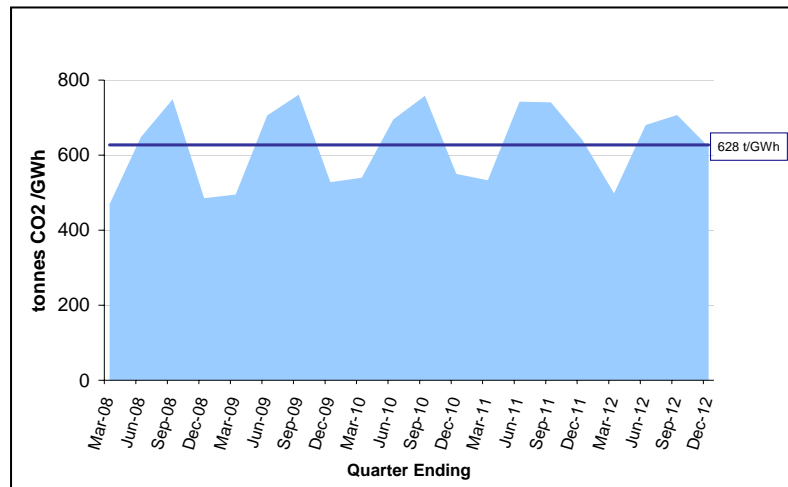

Given the objective has been to identify an emission factor for the initial Kyoto commitment period, it seems appropriate to use the expected change in emissions per GWh over the full five year period.

8 SENSITIVITY ANALYSIS

Analysis has also been undertaken to check the sensitivity of the emission factor to a number of parameters.

Using gas at New Plymouth instead of oil and/or using additional gas at Huntly instead of extra coal when coal stocks are depleted in a dry year affected the base emission factor only marginally. For example, allowing for greater gas availability in dry years (albeit at a relatively high price), reduced the average emission factor from approximately 630 tonnes of CO₂ per GWh to just over 600 tonnes of CO₂ per GWh.

Similarly, using otherwise unutilised New Plymouth capacity on oil instead of sourcing additional coal at Huntly would only reduce the emission factor marginally by less than 5 tonnes of CO₂ per GWh. For this analysis, it was assumed that an average coal stock level between 0.5m and 1m tonnes would be maintained.

If greater coal flexibility and less gas flexibility were to occur, then the emission factor could be expected to rise because coal would be the marginal fuel more frequently. Alternatively, if coal were to be less flexible, and gas more flexible, then the emission factor would be lower. However, it is not considered likely that future gas supply arrangements will be as flexible as those enjoyed under the Maui supply.

Higher or lower demand would evolve over time and a corresponding supply-side response could be expected. Depending on the nature of such a supply side response, the average emission factor may alter little from the figure estimated here. For example, if some additional renewables or relatively inflexible additional coal supply were added the factor would not immediately change significantly. However, it is also possible that spare coal capacity at Huntly could be utilised with short term coal supply arrangements as happened in the winter of 2003, potentially raising the estimated emission factor.

Material changes to the core supply assumptions, such as Project Aqua being delayed or e3p not proceeding, could affect the emission factor more significantly depending on what alternative supply is assumed. The sensitivity of the emission factor to hydro supply in wet or dry years, as shown in Figure 10, provides an indication of the sensitivity of the emission factor to any major changes in core supply assumptions. Subject to any increased risk of hydro spill, a substantial amount of new renewables, for example, would tend to reduce the emission factor in the same manner that extra hydro supply in a wet year would.

9 CONCLUSIONS

The analysis presented in this report is based on a supply and demand scenario developed in consultation with Climate Change Office and Ministry of Economic Development staff.

It represents a view of how supply and demand might evolve over the next 9 years. Based on this analysis, an emission factor in the vicinity of 600 tonnes of CO₂ per GWh appears to be appropriate.

However, 9 years is a relatively long period over which to forecast with precision. Supply and demand trends will become clearer over time and it would be appropriate to reassess the emission factor from time to time and especially when significant new information comes to hand. Factors such as the Maui redetermination and the downward revision of Pohokura reserves, for example, have demonstrated how key assumptions can change over such a time frame as the study period in this analysis.